

## IGBT MODULE ( S-Series )

### ■ Features

- NPT-Technology
- Square SC SOA at  $10 \times I_C$
- High Short Circuit Withstand-Capability
- Small Temperature Dependence of the Turn-Off Switching Loss
- Low Losses And Soft Switching

### ■ Applications

- High Power Switching
- A.C. Motor Controls
- D.C. Motor Controls
- Uninterruptible Power Supply

### ■ Outline Drawing

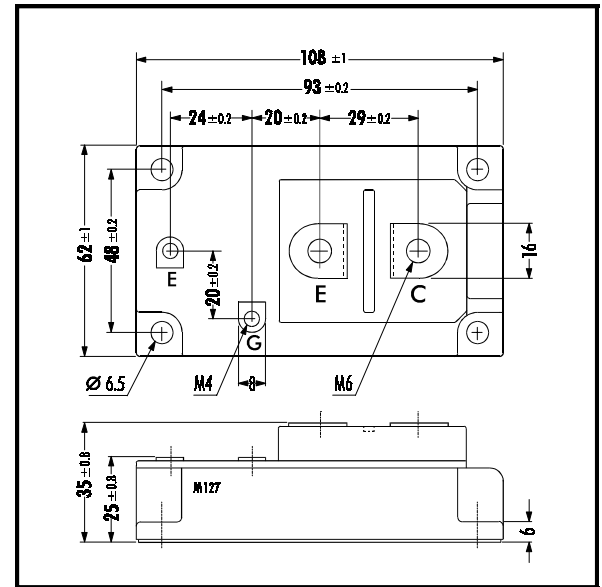

### ■ Maximum Ratings and Characteristics

#### • Absolute Maximum Ratings ( $T_c=25^\circ\text{C}$ )

Items	Symbols	Ratings	Units		
Collector-Emitter Voltage	$V_{CES}$	1200	V		
Gate -Emitter Voltage	$V_{GES}$	$\pm 20$			
Collector Current	$I_C$	400 / 300	A		
	1ms	25°C / 80°C		$I_{C\ PULSE}$	800 / 600
	Continuous			$-I_C$	300
	1ms			$-I_{C\ PULSE}$	600
Max. Power Dissipation	$P_C$	2100	W		
Operating Temperature	$T_j$	+150	°C		
Storage Temperature	$T_{stg}$	-40 ~ +125			
Isolation Voltage *1	A.C. 1min.	$V_{is}$	2500	V	
Screw Torque	Mounting *2	3.5	Nm		
	Terminals *2	4.5			
	Terminals *2	1.7			

Note: 1\*: All Terminals should be connected together when isolation test will be done.  
2\*: Recommendable Value: Mounting 2.5 – 3.5 Nm (M5) or (M6) ; Terminal 3.5 – 4.5 Nm (M6), 1.3 – 1.7 Nm (M4)

### ■ Equivalent Circuit

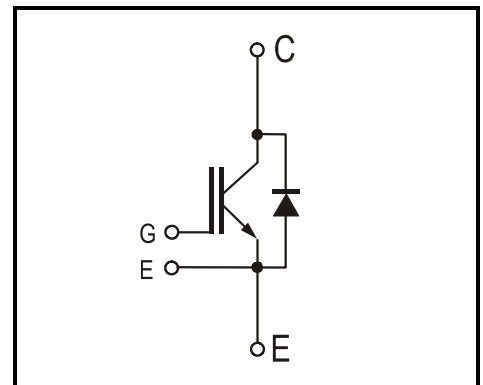

#### • Electrical Characteristics ( at $T_j=25^\circ\text{C}$ )

Items	Symbols	Test Conditions	Min.	Typ.	Max.	Units
Zero Gate Voltage Collector Current	$I_{CES}$	$V_{GE}=0V$ $V_{CE}=1200V$			4.0	mA
Gate-Emitter Leakage Current	$I_{GES}$	$V_{CE}=0V$ $V_{GE}=\pm 20V$			800	nA
Gate-Emitter Threshold Voltage	$V_{GE(th)}$	$V_{GE}=20V$ $I_C=300mA$	5.5	7.2	8.5	V
Collector-Emitter Saturation Voltage	$V_{CE(sat)}$	$V_{GE}=15V$ $I_C=300A$		$T_j = 25^\circ\text{C}$ 2.3 $T_j = 125^\circ\text{C}$ 2.8	2.6	
Input Capacitance	$C_{ies}$	$V_{GE}=0V$		36'000		pF
Output Capacitance	$C_{oes}$	$V_{CE}=10V$		7'500		
Reverse Transfer Capacitance	$C_{res}$	$f=1MHz$		6'600		
Turn-on Time	$t_{ON}$	$V_{CC} = 600V$		0.35	1.2	μs
	$t_{r,x}$	$I_C = 300A$		0.25	0.6	
	$t_{r,i}$	$V_{GE} = \pm 15V$		0.10		
Turn-off Time	$t_{OFF}$	$R_G = 2.7\Omega$		0.45	1.0	μs
	$t_f$	Inductive Load		0.08	0.3	
Diode Forward On-Voltage	$V_F$	$I_F=300A$ ; $V_{GE}=0V$	$T_j = 25^\circ\text{C}$ 2.3 $T_j = 125^\circ\text{C}$ 2.0		3.0	V
Reverse Recovery Time	$t_{rr}$	$I_F=300A$			350	ns

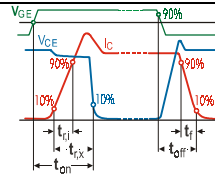

#### • Thermal Characteristics

Items	Symbols	Test Conditions	Min.	Typ.	Max.	Units
Thermal Resistance	$R_{th(j-c)}$	IGBT			0.06	°C/W
	$R_{th(j-c)}$	Diode			0.17	
	$R_{th(c-f)}$	With Thermal Compound		0.0125		

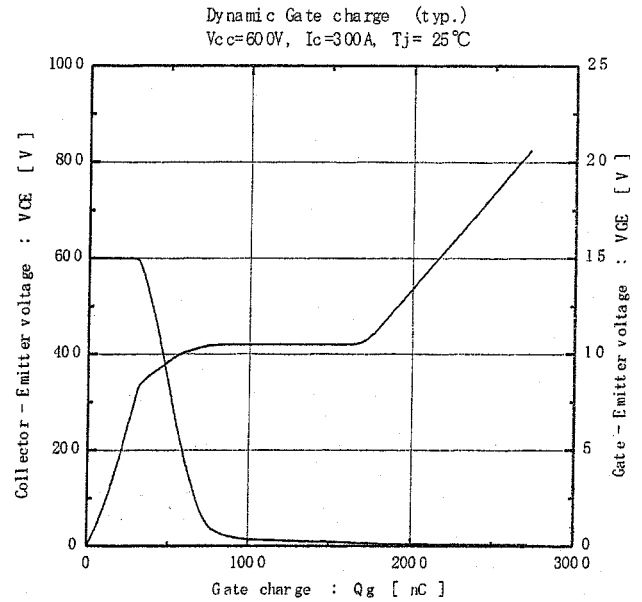
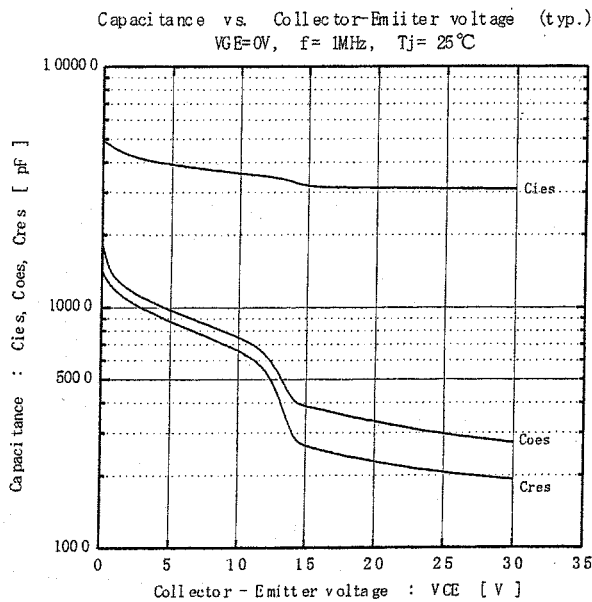
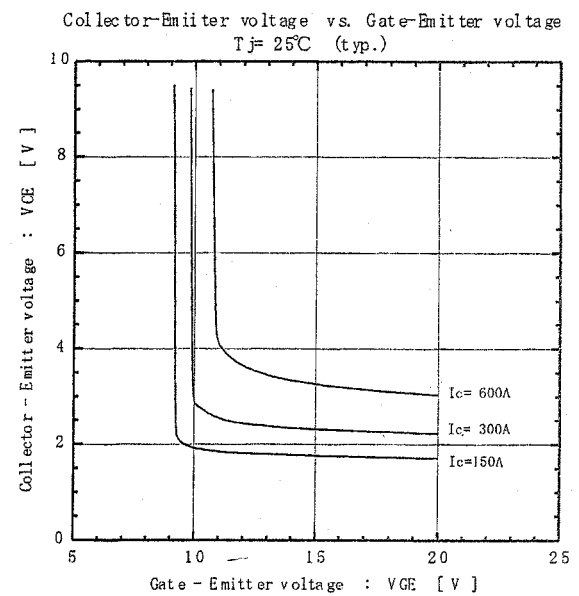
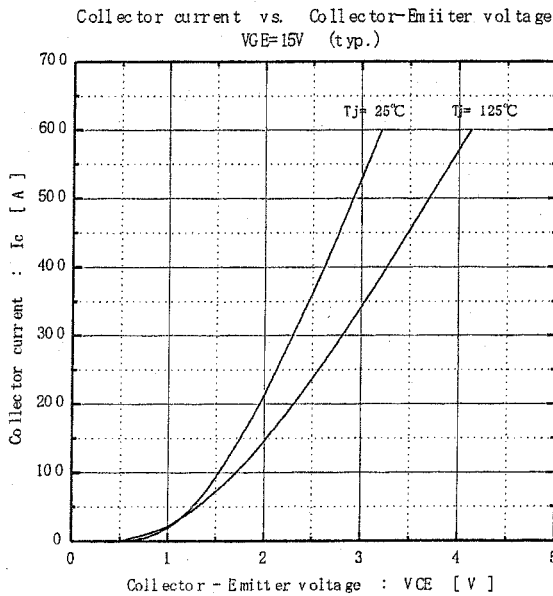
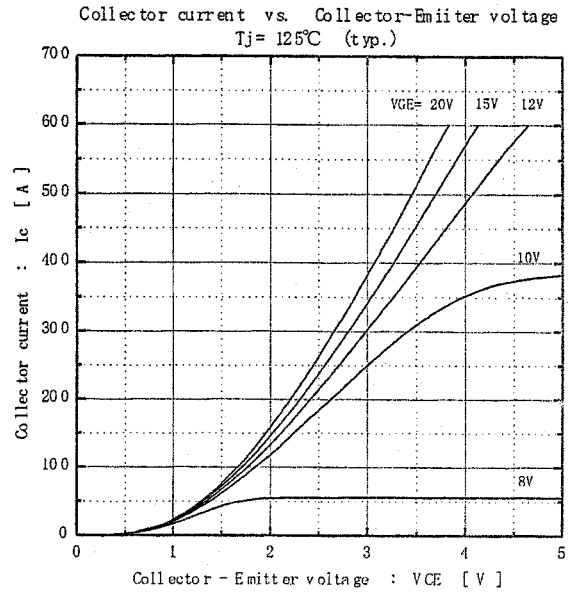
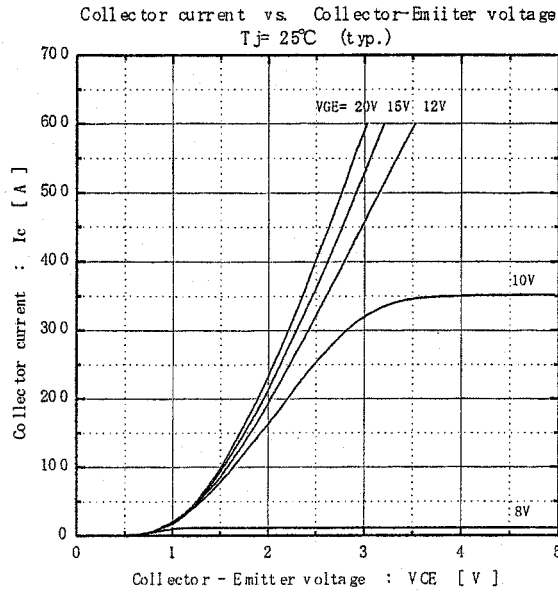

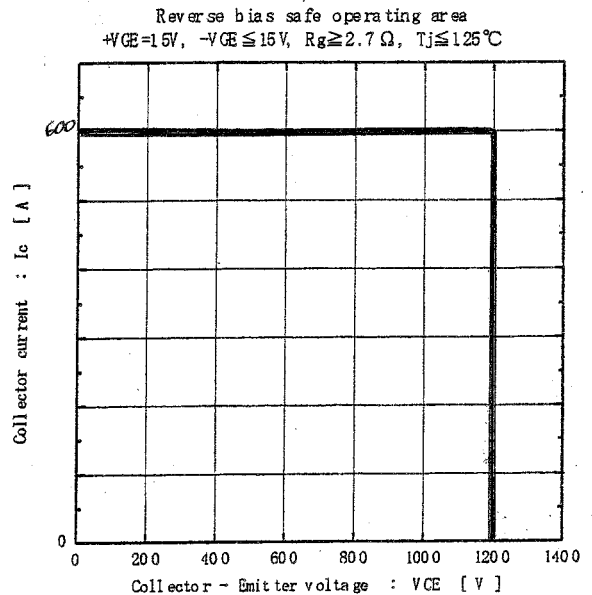
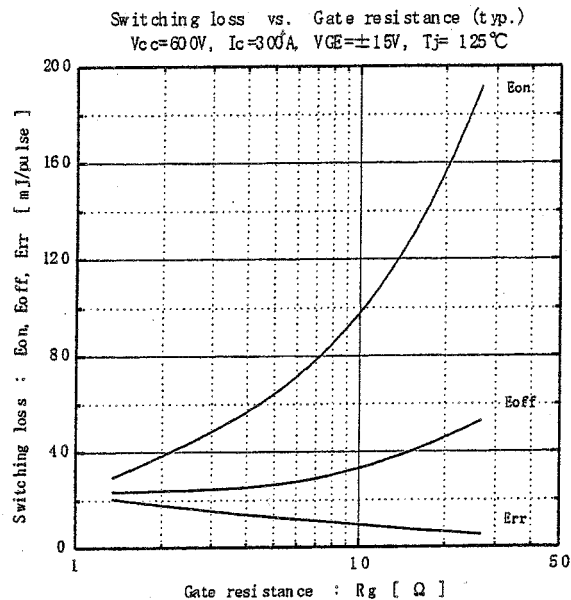
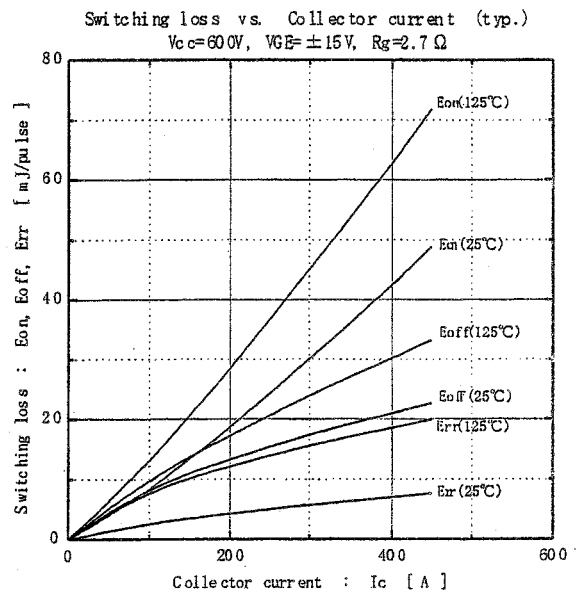
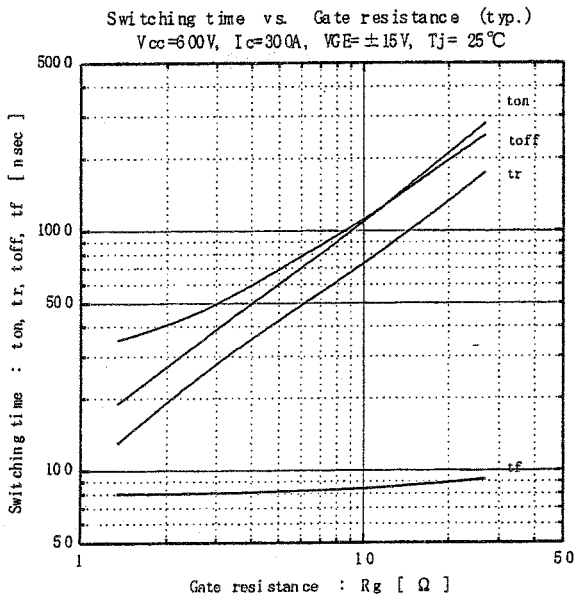
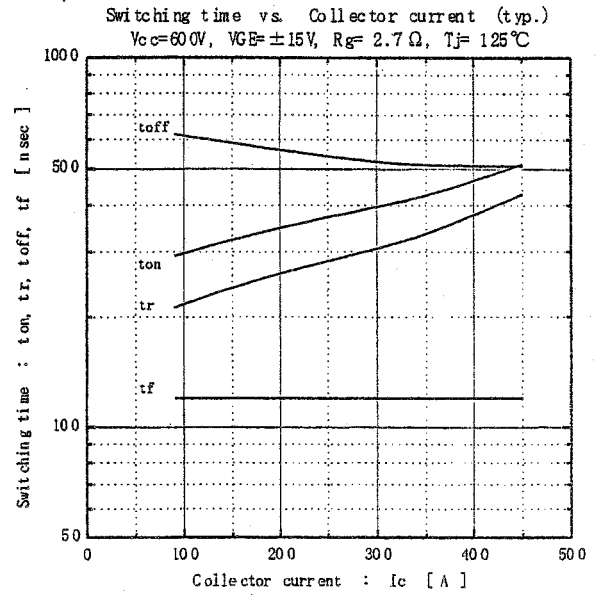
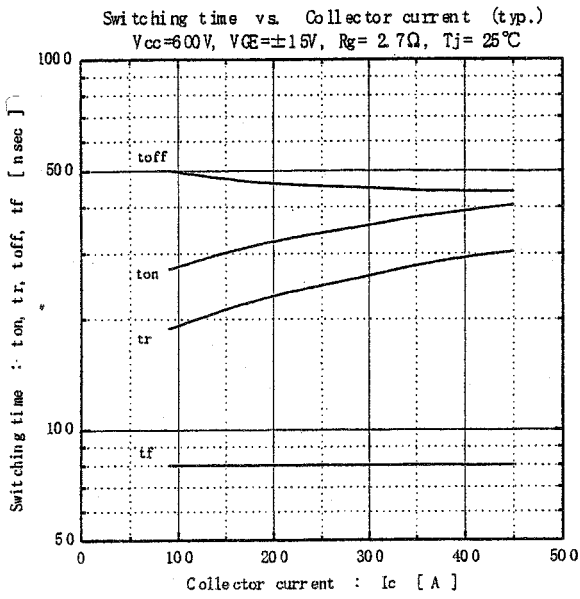

Forward current vs. Forward on voltage (typ.)

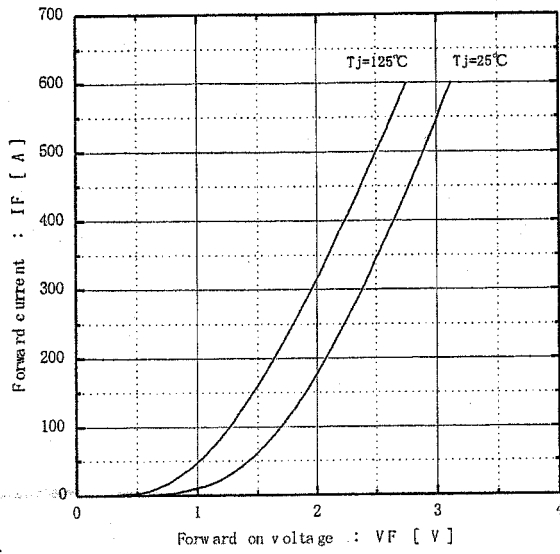

Reverse recovery characteristics (typ.)  
V<sub>cc</sub>=600V, V<sub>GE</sub>=±15V, R<sub>g</sub>=2.7Ω

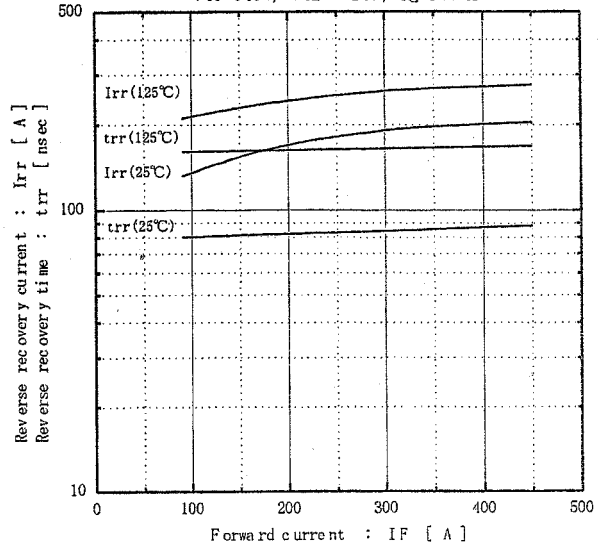

Transient thermal resistance

